

# MV "SCOTIAN SENTINEL"

## EMERGENCY RESPONSE AND RESCUE VESSEL

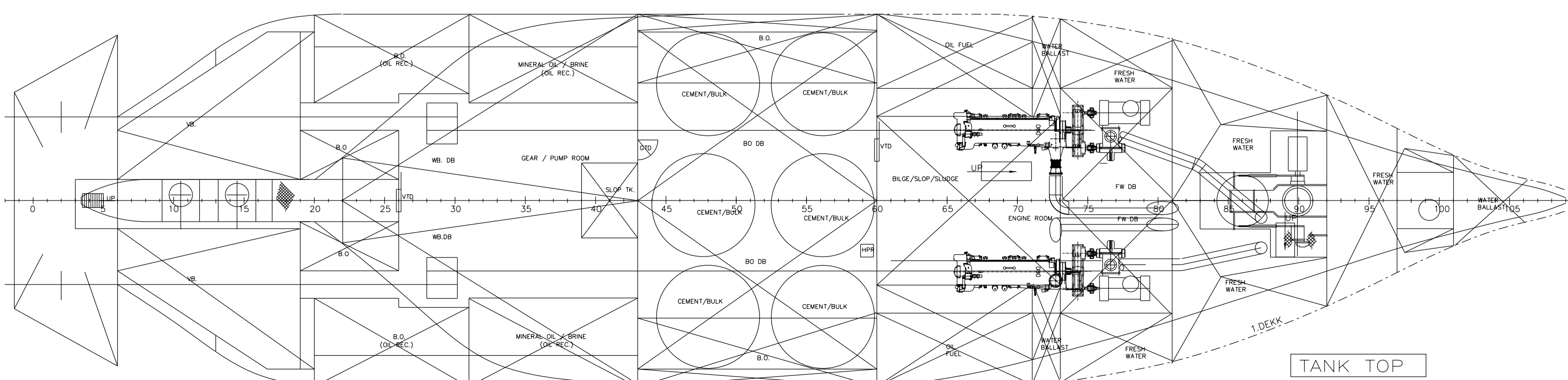
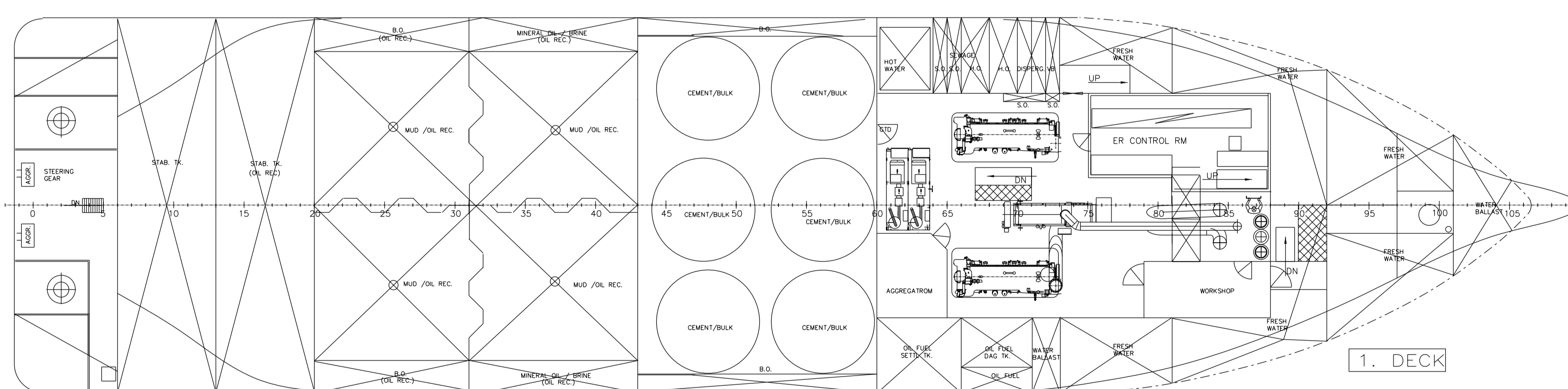
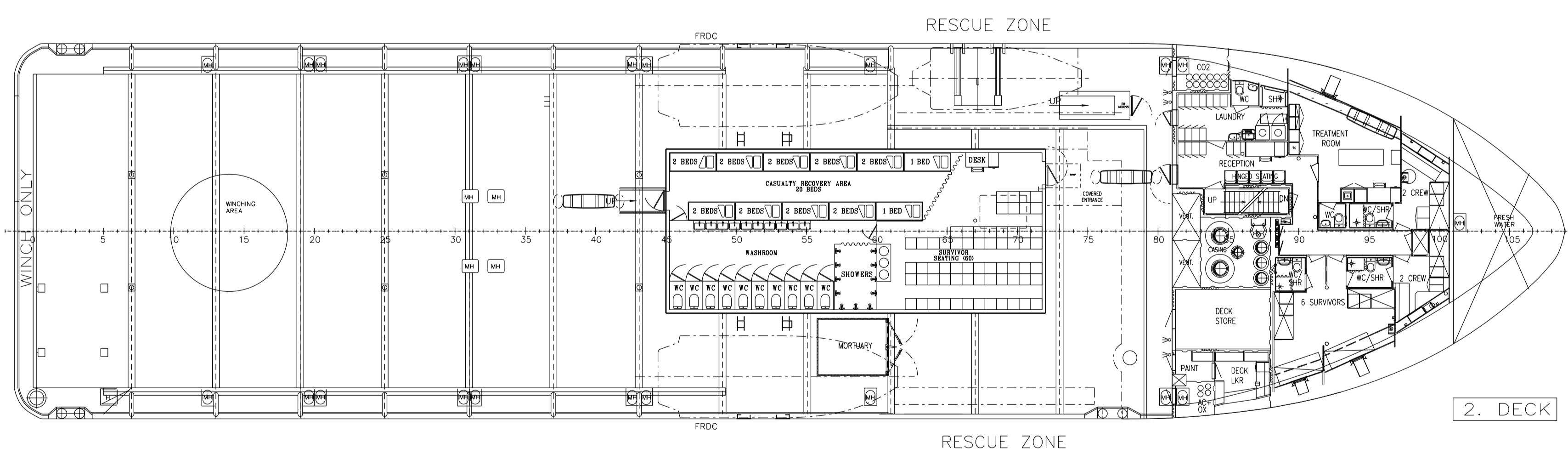
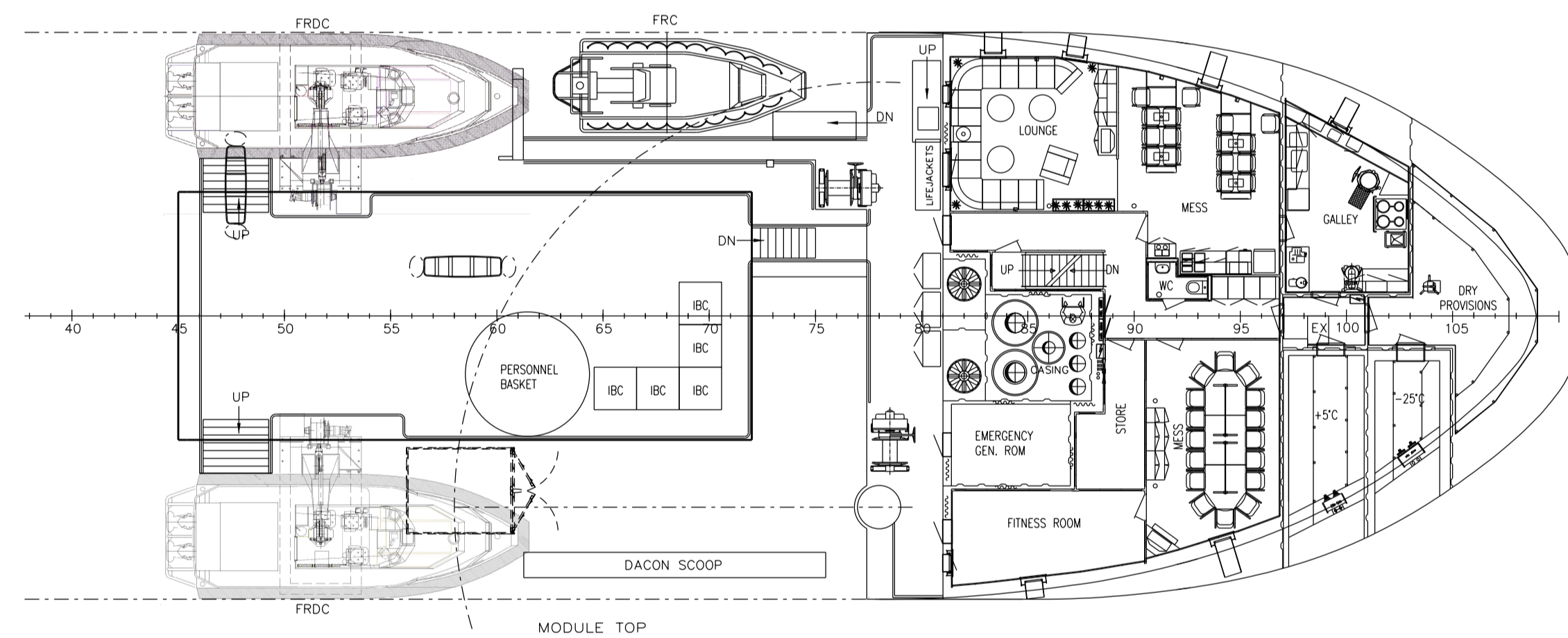
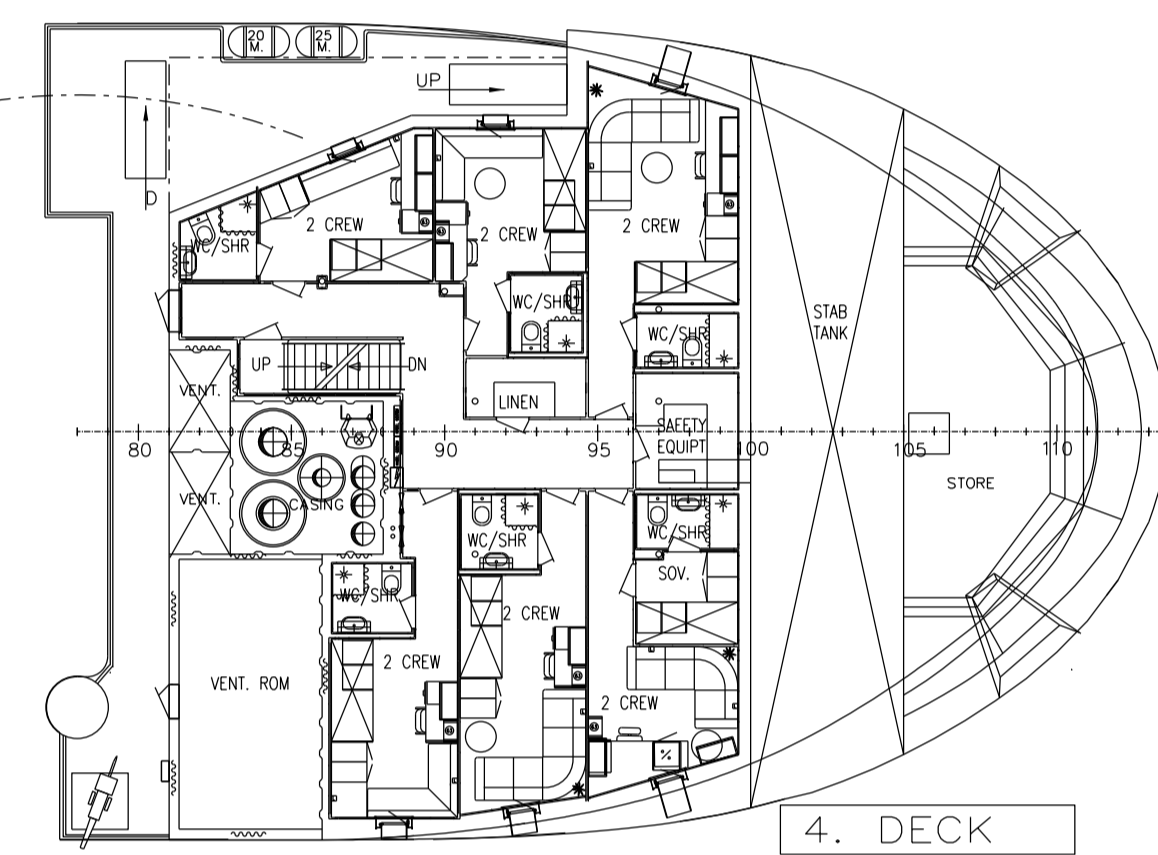
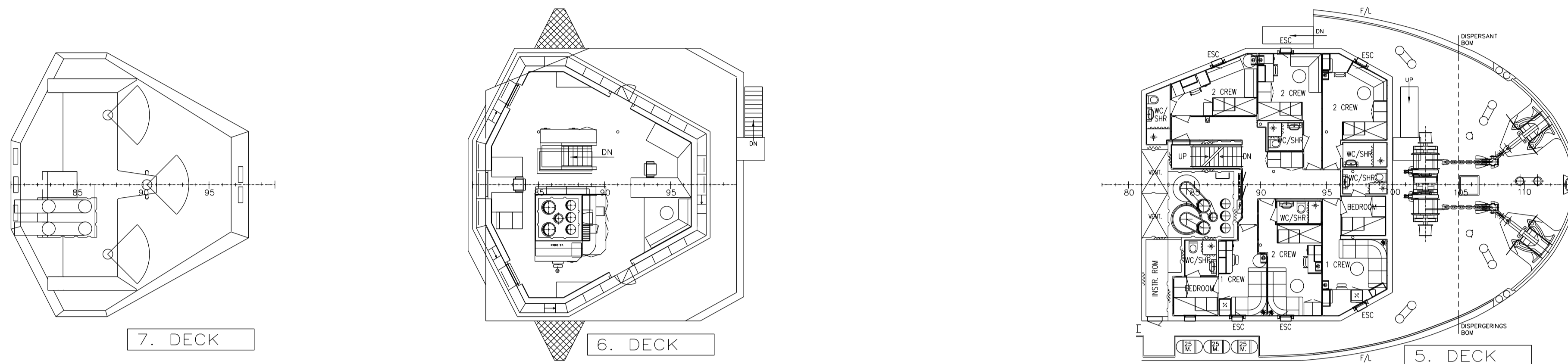
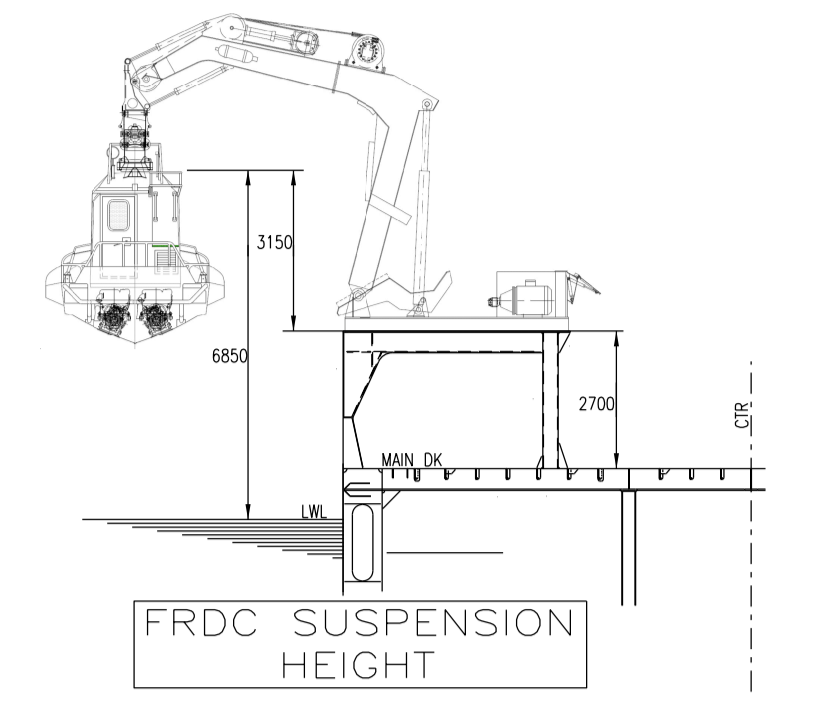
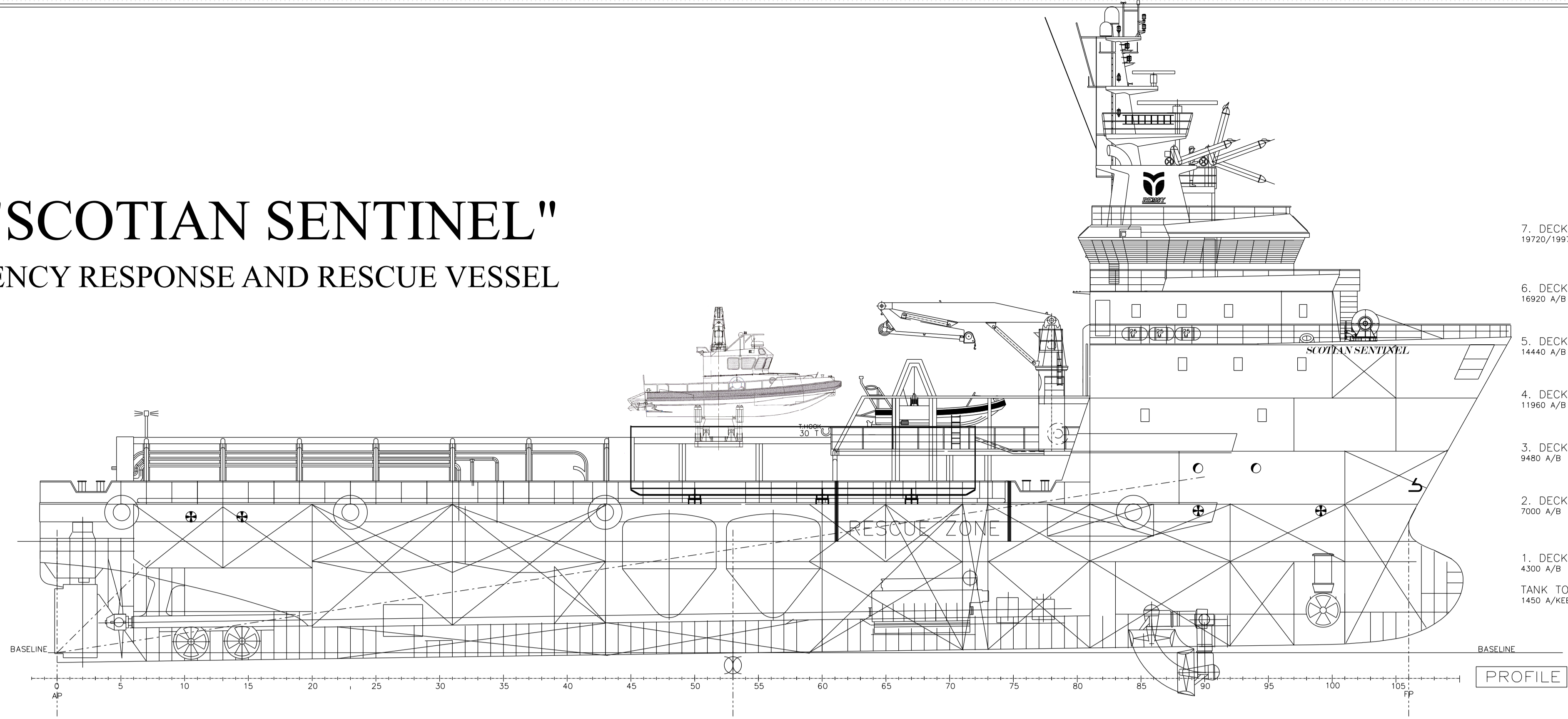

### SURVIVOR FACILITIES

- SURVIVORS (300+)
- SURVIVOR SEATS (66)
- SHRs (13)
- WCs (13)
- WHBs (13)
- RECOVERY BERTHS (26 (2 SINGLE))
- MORTUARY (13)

### RESCUE EQUIPMENT

- 2 X FAST RESCUE DAUGHTER CRAFT
- 1 X FAST RESCUE CRAFT
- DACON SCOOP
- RESCUE BASKET
- RESCUE ZONE P&S

### PRINCIPAL DIMENSIONS:

|             |         |
|-------------|---------|
| LENGTH OA   | 69,00 M |
| LENGTH BP   | 63,60 M |
| BREADTH MLD | 16,00 M |
| DEPTH MLD   | 7,00 M  |
| COMPLEMENT  | 15      |

CLASSIFICATION:  
DnV +1A1, SUPPLY VESSEL, E0, SF, FiFi I&II,  
OILREC, DYNPOS AUT, HL(2,5), DK(5,0)

| REV. | MODIFICATION   | BY  | DATE     | CHKD. | DATE     |
|------|----------------|-----|----------|-------|----------|
| B    | GENERAL UPDATE | ADR | 24/1/19  | IAN   | 24/1/19  |
| A    | GENERAL UPDATE | ADR | 19/11/18 | IAN   | 19/11/18 |

|               |  |
|---------------|--|
| APPROVED BY:- |  |
| DATE:-        |  |

|            |   |              |           |
|------------|---|--------------|-----------|
| TITLE:-    | SCOTIAN SENTINEL<br>GENERAL ARRANGEMENT | REF:-        |           |
| DRAWN BY:- | ADR                                     | CHECKED BY:- | IAN       |
| DATE:-     | 27/8/18                                 | DATE:-       | 27/8/18   |
|            |   | SCALE:-      | 1:50 @ A0 |

THIS DRAWING AND THE INFORMATION IT CONTAINS ARE THE PROPERTY OF MACDUFF SHIP DESIGN LTD. IT IS NOT TO BE TRACED, COPIED OR PUBLISHED WITHOUT OUR WRITTEN CONSENT OR MISUSED IN ANY WAY.

MACDUFF SHIP DESIGN Ltd. LOW SHORE MACDUFF  
ABERDEENSHIRE SCOTLAND AB44 1RE  
TEL 01261 833825 FAX 01261 833835  
EMAIL info@macduffshipdesign.com